

your global specialist

We have a system
for effective lubrication.

Klübermatic lubricant dispensers





The right lubricant at the right point at the right time

The right lubricant at the right point at the right time	3
Automatic lubrication with Klübermatic – your benefits at a glance	4
The right solution for every application	5
Klübermatic FLEX	6
Klübermatic NOVA	8
Klübermatic STAR VARIO	10
Klübermatic STAR CONTROL	12
Klübermatic PRO MP-6 and PRO LINE	14
Klübermatic PRO C MP-6 and PRO C LINE	16
Klübermatic product range	18
Selected Klübermatic accessories	20
Installation example	22

Correct lubrication is what matters

In technical equipment, any contact between materials like metal or plastic causes friction and tends to induce wear. Lubricants that are tailor-made for individual components prevent bearings, gears or chains from wear damage or even failure.

This is what Klüber Lubrication specialises in: the development of speciality lubricants for all branches of industry, all significant components and almost any challenging application.

Solutions with added value for you

The lubricant is an element contributing to improved functionality and efficiency of plants and machines, or making technical solutions feasible in the first place. For you, this entails longer component life, lower energy consumption, less maintenance, and hence maximum equipment profitability. High-end lubricants are used by companies in sectors as varied as food processing, the wind energy industry, steel-making, base materials, pharmaceutical, chemical and many other fields. Our customers appreciate our comprehensive solutions supporting them especially in the challenges of today, such as process cost optimisation and maximising efficiency.

Klüber Lubrication – the globally leading company for speciality lubricants

Whether components operate under extreme temperatures or at high speeds, are subjected to extreme pressure or exposed to aggressive environmental influences: with its range of approximately 2,000 different speciality lubricants sold directly worldwide, Klüber Lubrication offers the right solution – backed

by intensive consultation and special services. Should the right solution for a particular tribological requirement not be found among our product range, Klüber Lubrication will tailor-develop a lubricant in close cooperation with the customer. Through constant dialogue with our customers and regular customer audits, we learn about their individual wishes and give them top priority. All Klüber Lubrication manufacturing plants worldwide are certified according to quality standards (DIN/ISO/TS 16949 or DIN EN ISO 9001), environmental standards (DIN EN ISO 14001 or eco-audit) as well as an occupational safety standard (OHSAS 18001). Furthermore, some of our facilities have been certified according to DIN EN ISO 21469, a standard for lubricants to be used in critical sections of food and pharmaceutical production.

Systems for the automatic lubrication of your plants

We at Klüber Lubrication regard ourselves as suppliers of solutions, which is why we offer not only high-performance oils and greases, but an “intelligent package” as well, which will take care of the automatic lubrication of your equipment and components. A selection of our lubricant range covering many typical applications can be obtained in automatic lubricant dispensers for single-point lubrication. These thoughtfully designed and proven systems based on electro-mechanical or electro-chemical technology can be fitted with standard, long-term or extreme-pressure greases, standard chain oils or high-temperature chain oils, or a special food-grade grease or oil. Apart from this standard range, you can also obtain other lubricants in automatic dispenser systems on request for higher order volumes – provided their use has been tested and approved. Just talk to your contact at Klüber Lubrication.

Automatic lubrication with Klübermatic – your benefits at a glance

The right solution for every application

Profitability

With uninterrupted production processes and reliable maintenance intervals, production downtime is reduced to a minimum. Continuous, maintenance-free long-term lubrication and a constantly high lubricant quality ensure high machine availability. The permanent supply of fresh lubricant to the friction point keeps friction low and thus helps to reduce energy costs considerably.

→ **Klübermatic lubrication reduces costs by up to 25 %**

Reliability

Automatic lubricating systems offered by Klüber Lubrication ensure reliable, clean and accurate lubrication 24 hours a day, over many years. Machine availability is safeguarded as there is always fresh lubricant at the friction point.

→ **Klübermatic lubrication helps to prevent up to 55 % of rolling bearing failures**

Safety

Longer maintenance intervals means that the frequency of maintenance works and staff having to work within dangerous areas is reduced. So, if lubricant dispensers from Klüber Lubrication are used in areas that are difficult to access, the risk level at the workplace decreases considerably.

→ **Klübermatic lubrication reduces risk of accidents by up to 90 %**

From low-cost to high-end – automatic systems meeting any challenge

These technical solutions are offered by Klüber Lubrication:

- freely selectable lubrication intervals, incrementally from 1 – 12 months
- a variety of lubricants
- self-controlled or PLC-controlled lubrication systems (programmable time control)
- a combination of proven lubricant from Klüber Lubrication and automatic lubricant dispenser



Food-processing industry

In the food-processing industry, lubrication has an effect on food safety as well as on operating costs and productivity. Klüber Lubrication offers a comprehensive range of synthetic high-performance lubricants for the food sector. Several of them can also be obtained in automatic lubricant dispensers for clean, reliable and economical lubrication. This is particularly beneficial with regard to stringent hygiene requirements. Most of these lubricants are registered as NSF H1 and certified under ISO 21469, and as halal and kosher.



Steel industry

Temperatures and other ambient conditions in the steel industry are tough, both for lubricants and their application. Many lubrication points are difficult to access or require particular safety precautions. Some of them can only be supplied when the machinery is standing still, which is of course a highly undesirable state for any equipment. To improve safety, reliability and machine availability, Klüber Lubrication offers not only the right lubricant but also a practical solution for its application in the form of an automatic lubricant dispenser.



Base materials industry

Extreme temperatures, operation under heavy loads twelve months a year, tons of cement dust – such extreme conditions are commonplace in the cement industry around the world. Klüber Lubrication offers lubricants for all parts of a cement plant. Many decades of experience have shown that use of the right lubricant can help to reduce wear and costs and enhance machine reliability. Lubrication points that are located far apart, or may pose a particular safety risk to employees, can be continuously and reliably supplied by automatic lubricant dispensers with little effort.



Chemical and pharmaceutical industries

In these industries, requirements and safety standards to be met by lubricants are particularly stringent. Any risk of contamination is to be avoided – which makes automatic lubricant dispensers an obvious choice. Accurate automatic metering also supports compliance with the many applicable guidelines. Klüber Lubrication has a wide range of lubricants registered as NSF H1 especially for the pharmaceutical industry. These lubricants, as well as the associated manufacturing processes, are also certified under ISO 21469.

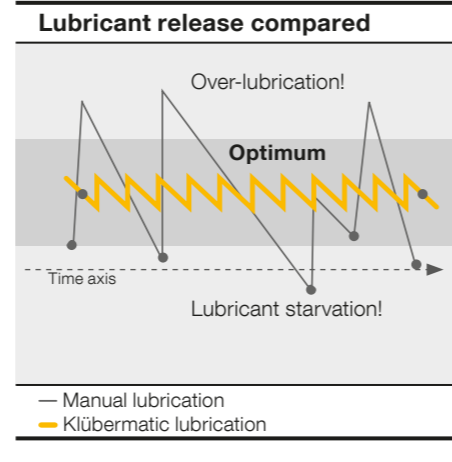
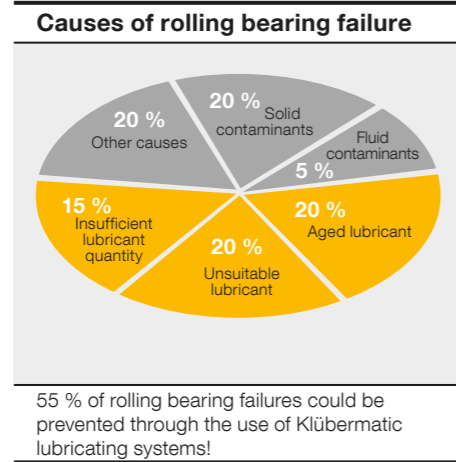
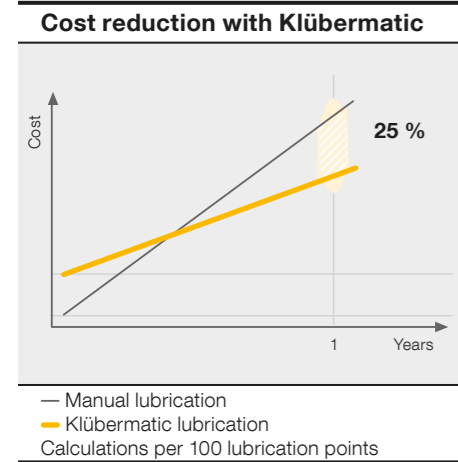

Klübermatic FLEX

The compact and flexible lubrication unit

Flexible – for use in demanding applications

Klübermatic FLEX is a compact, ready-to-use lubricator. It can be used for diverse applications at temperatures between $-20\text{ }^{\circ}\text{C}$ and $+60\text{ }^{\circ}\text{C}$. The lubrication interval can be selected in monthly increments between 1 and 12 months. An electronically controlled chemical reaction generates the pressure to ensure continuous fresh lubricant supply to the lubrication point at set intervals. Klübermatic FLEX is available in volumes of 60 cm^3 and 125 cm^3 .

Applications

Klübermatic FLEX is particularly suitable for single-point lubrication in rolling and plain bearings, slideways, open gears, toothed racks, shaft seals and chains. The lubrication system is dust-tight and protected against splash water (according to IP 68).



Dispenser characteristics	Your benefit
Complete system with regulation of dispensing intervals	- No assembly necessary, as the system is provided as a complete unit - Rotary switch for activation without tools
Lubrication interval can be set between 1 and 12 months and switched on and off as required	- Longer service life of installations and machine elements, as the dispensing time is adjusted to the requirements of the lube point - High availability of installation due to reliable lubricant supply
Service temperature range from -20 to $+60\text{ }^{\circ}\text{C}$ (-4 to $140\text{ }^{\circ}\text{F}$)	- Can be used in outdoor applications - Flexible, for use in cold and hot environments
Type of protection IP 68	- Good protection against water and contamination - Can be used in very humid or dusty environments

Technical information

Housing

Transparent plastic

Drive

Gas generating unit

Dispensing time

1, 2, 3, ..., 12 months

Lubricant volume

60 cm^3 and 125 cm^3

Temperature limits for the mechanical component

-20 to $+60\text{ }^{\circ}\text{C}$ (-4 to $140\text{ }^{\circ}\text{F}$)

Pressure build-up

Max. 5 bar

Type of protection

IP 68

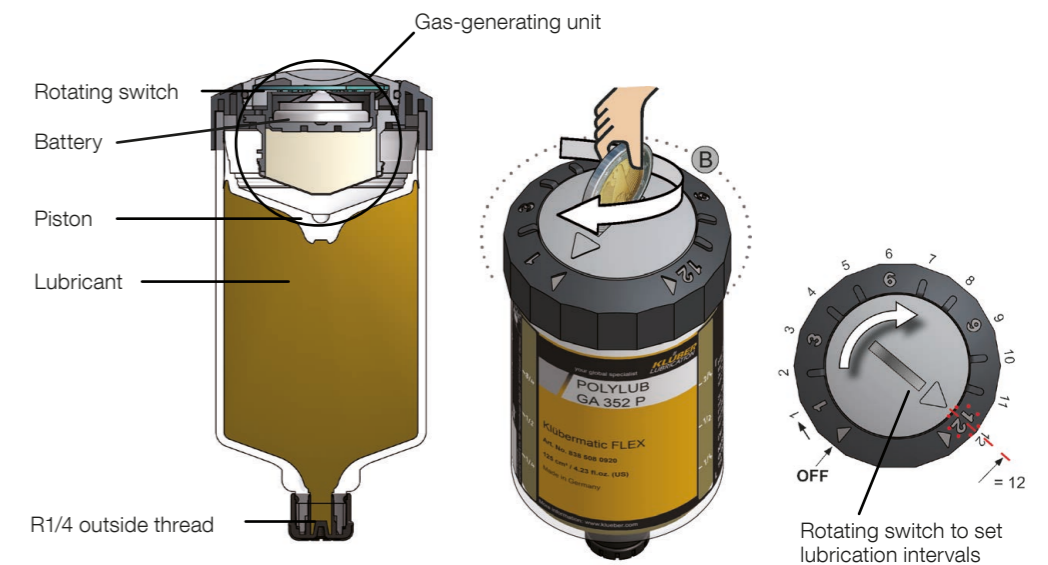

Klübermatic NOVA

Temperature-independent electrochemical lubrication system

For applications subject to strong temperature fluctuations

Klübermatic NOVA can be used for all applications between $-20\text{ }^{\circ}\text{C}$ and $+60\text{ }^{\circ}\text{C}$. On the Klübermatic NOVA control unit, a discharge period from 1 to 12 months can be set by push-button. The control unit will then calculate the amount of gas required for constant and reliable lubricant release over that time, taking into account the ambient temperature. Klübermatic NOVA consists of a reusable control unit, an LC unit (LC = lubricant canister) with integrated oil retention valve – filled with 125 cm^3 of grease or oil – and a protection cover.

Applications

Klübermatic NOVA is particularly useful for the single-point lubrication of rolling and plain bearings, slideways, open gears, toothed racks, shaft seals and chains operating over a wide ambient temperature range (e.g. open-air applications). The lubricating system is dust-tight and protected against splash water (acc. to IP 65) provided it is properly assembled.



Dispenser characteristics	Your benefit
Electronic control unit with integrated temperature compensation	<ul style="list-style-type: none"> – Simple handling – Temperature-independent lubricant metering for the whole dispensing time, as the temperature is automatically considered when setting the running time – Quick start-up (within one day), thus the lube point is provided with lubricant immediately after activation – Reusable control unit
LCD and push-button control	<ul style="list-style-type: none"> – Variable discharge period from 1 to 12 months – Discharge period can be adjusted to changing requirements any time – Constant condition monitoring possible due to display function
Service temperature range from $-20\text{ to }+60\text{ }^{\circ}\text{C}$ ($-4\text{ to }140\text{ }^{\circ}\text{F}$)	<ul style="list-style-type: none"> – Universal use over a wide temperature range, also under varying ambient temperatures
Ex-proof certification IP 65	<ul style="list-style-type: none"> – Use in spaces with explosion risk – Improved workplace safety

Technical information

Housing

Transparent plastic

Drive

Electrochemical reaction involving gas generating cells and electronic temperature compensation

Dispensing time

1, 2, 3, ..., 12 months

Lubricant volume

125 cm^3

Temperature limits for the mechanical component

$-20\text{ to }+60\text{ }^{\circ}\text{C}$ ($-4\text{ to }140\text{ }^{\circ}\text{F}$)

Pressure build-up

Max. 6 bar

Type of protection

IP 65

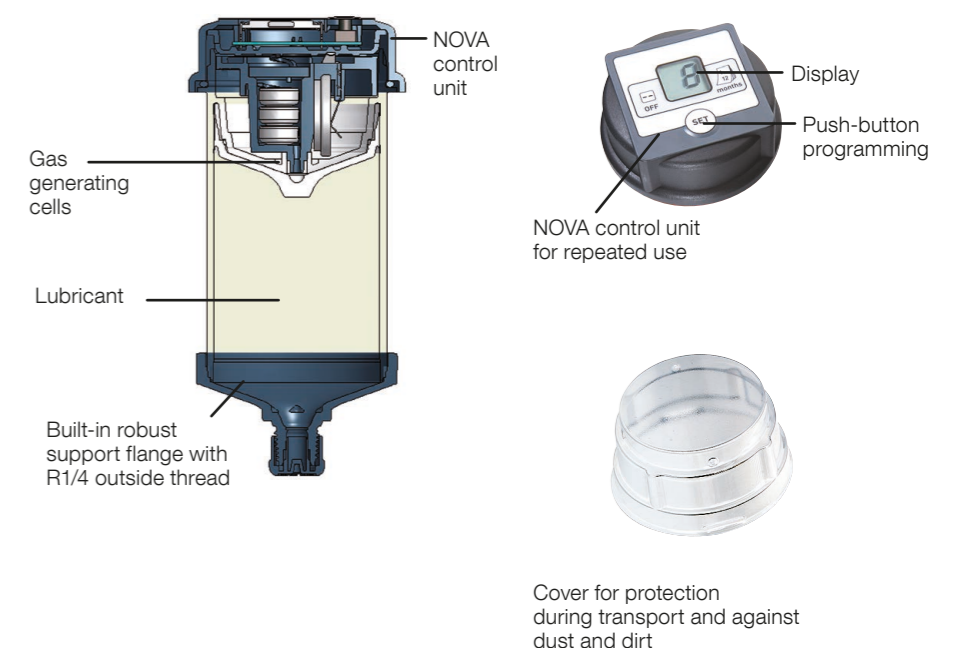

Klübermatic STAR VARIO

Fully automatic precision lubrication

Precise metering and adjustable lubricant amount

Klübermatic STAR VARIO is a fully automatic, temperature and pressure independent system for very precise lubricant metering. The system consists of an electromechanical drive, an LC unit (LC = lubricant canister) with 60 cm³, 120 cm³ or 250 cm³ lubricant and batteries. Set the required dispensing time and LC size via the push button and find your settings immediately on the LCD display.

The current operating condition is indicated through clearly visible LED signals (red/green) and on the LCD display. The LED signals can also be seen from a distance.

Applications

Klübermatic STAR VARIO is used for the single-point lubrication of rolling and plain bearings, slideways, open gears, toothed racks, threaded spindles, shaft seals and chains. With its high-precision lubricant metering, Klübermatic STAR VARIO may be used under strongly varying ambient temperatures and with different pressure requirements, e.g. for the lubrication of electric motors. The lubricating system is protected against dust and splash water provided it has been properly assembled.



Dispenser characteristics	Your benefit
Electromechanical drive with batteries	– Independent of temperature and vibration – One-time purchasing costs, as it is reusable
LED warning lights	– Red/green signals enable rapid checking of operation
LCD display with push button control Displays dispensing time, LC volume and operating state	– Simple, self-explanatory operation – Precise settings prevent lubrication starvation and save lubricant – Settings can be changed any time (1, 2, 3, ... 12 months and LC volume) – Can be switched off during downtime
Constant pressure build-up of max. 6 bar	– Remote installation with tubing of up to five metres (e.g. in high-temperature areas) – Increased workplace safety due to assembly outside danger zones – Higher plant availability as exchange can be made while machine is running
System purges	– Lubrication point can be flushed to dissolve blockages

Technical information

Housing

Transparent plastic

Drive

Electromechanical, reusable

Power supply

Klübermatic VARIO STAR battery set 4.5 V

Dispensing time

1, 2, 3, ..., 12 months

Lubricant volume

60 cm³, 120 cm³ or 250 cm³

Temperature limits for the mechanical component

–10 to +60 °C (+14 to +140 °F)

Constant pressure build-up

Max. 6 bar

Type of protection

IP 65

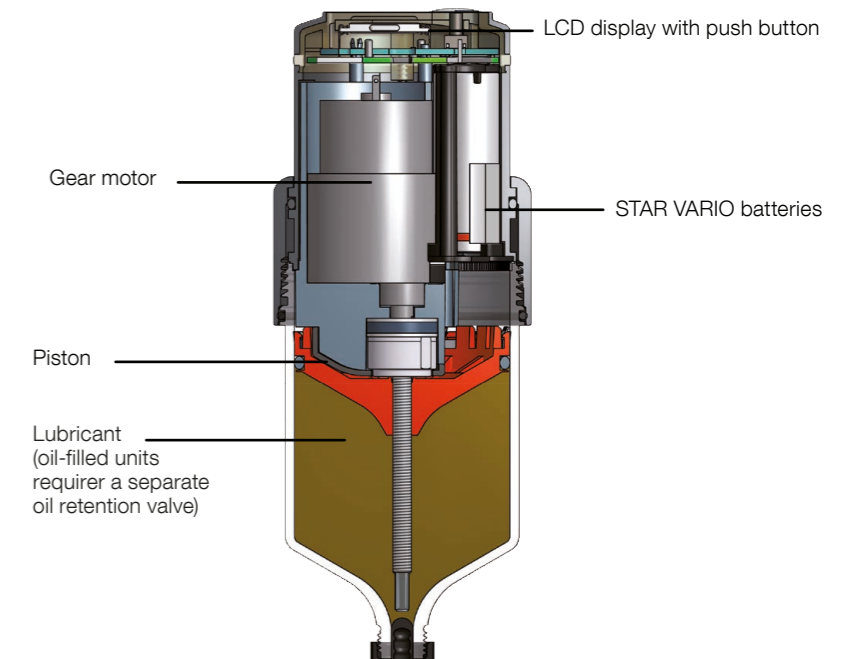

Klübermatic STAR CONTROL

Individual automatic relubrication by means of external control

Accurate lubricant supply – constant and temperature-independent

Klübermatic STAR CONTROL supplies the lubrication point with oil or grease immediately on starting – ensuring constant, accurate and temperature-independent lubrication. Klübermatic STAR CONTROL is power-supplied directly from the machine it is connected to and can be linked up to the machine's PLC unit for control and monitoring. Klübermatic STAR CONTROL automatically discharges a set amount of lubricant as long as it remains connected to power. The LC unit (LC = lubricant canister) is available with 60 cm³, 120 cm³ or 250 cm³ of lubricant.

Applications

Klübermatic STAR CONTROL can be used for the lubrication of rolling and plain bearings, slideways, open gears, toothed racks, threaded spindles, shaft seals and chains. This lubricating system operates with great accuracy in all machines where lubrication is required in line with machine runtimes and where over-lubrication is to be avoided. Connection to the machine's PLC is possible. The lubricating system is protected against dust and splash water provided it has been properly assembled.

Hint:

Klübermatic STAR CONTROL includes the operating modes TIME and IMPULSE which allow a flexible use. In the TIME mode, the lubricating system discharges according to operating hours, in the IMPULSE mode a precisely set quantity is dispensed as soon as voltage is applied.



Dispenser characteristics	Your benefit
Machine-based control, e.g. via PLC	<ul style="list-style-type: none"> – Flexible control and additional monitoring as the the lubricating system can be linked up to the machine – Connection to the machine enables automatic system switch-on and off – Integration in fault alert system possible – Efficient lubricant use
Power supply from machine/installation	<ul style="list-style-type: none"> – Constant power supply – No battery change required
Reusable drive	<ul style="list-style-type: none"> – Accurate, lubrication point-specific metering – Transparent housing enables visual fill level inspection
Constant pressure build-up of max. 6 bar	<ul style="list-style-type: none"> – Longer availability of installation as the change can take place during operation – Increased workplace safety due to automatic lubricant supply to lube points difficult to access, assembly is possible up to 5 metres outside the danger zone in an easily accessible place
System purges	<ul style="list-style-type: none"> – Lubrication point can be flushed to dissolve blockages

Technical information

Housing

Transparent plastic

Drive

Electromechanical, reusable

Power supply

External 9–30 V DC, I_{max} 0,5 A

Runtime

Time-controlled (TIME)
Impulse-controlled (IMPULSE)

Lubricant volume

60 cm³, 120 cm³ or 250 cm³

Temperature limits for the mechanical component

–20 to +60 °C (–4 to 140 °F)

Constant pressure build-up

Max. 6 bar

Type of protection

IP 65

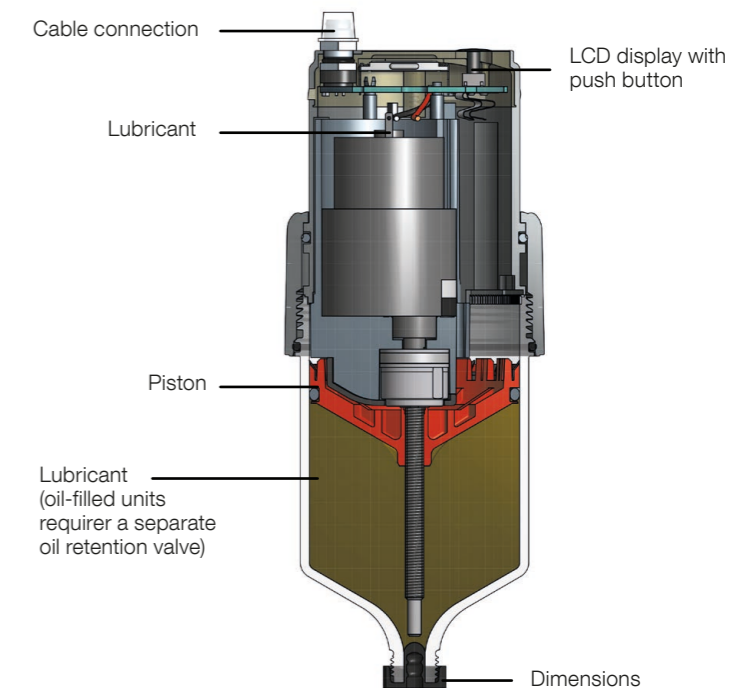

Klübermatic PRO MP-6 and PRO LINE

Self-contained multi-point lubrication system for max. 6 lubrication points

Precise lubricant supply even under extreme conditions

Klübermatic PRO MP-6 and PRO LINE are battery-powered multi-point lubrication systems. Depending on the dispensing time from one day to 24 months, 250 cm³ or 500 cm³ of lubricant is dispensed from max. 6 outlets to the lubrication points. Due to the pressure build-up of max. 25 bar, the lubricant is distributed without pressure loss even when using tubings of up to 5 metres (per outlet). This increases workplace safety and allows reliable lubrication when the system is running.

Applications

Applications of Klübermatic PRO MP-6 include: rolling and plain bearings, open gears, spindles, shaft seals of engines, generators, pumps and fans. Klübermatic PRO LINE is particularly suitable for the lubrication of linear guides, e.g. in robot systems. The dispensers are used in a variety of applications ranging from the automotive industry to the paper and steel industry.



Dispenser characteristics	Your benefit
Flexible settings possible (dispensing time in months, lubricant volume and pause time per outlet)	– Klübermatic PRO MP-6: Individual setting of dispensing time and lubricant volume – Klübermatic PRO LINE: The lubricant quantity to be dispensed can be set individually for each outlet – different quantities per outlet are possible with just one system
Push button with display and LED (for settings, display of the active outlets, display of the remaining dispensing time (PRO LINE) or of the remaining volume resp. (PRO MP-6))	– Easy handling and configuration of the lubricating system – Malfunctions of lubrication system are immediately displayed by the red/green LED light – Status control displayed saves time and makes planning of PRO LC (lubricant canister) exchange easier
Constant pressure build-up of max. 25 bar	– Assembly with tubing of up to 5 metres per outlet possible – Increases workplace safety in case of lubrication points difficult to access

Technical information

Housing

Transparent plastic

Drive

Battery-powered (PRO battery), reusable

Dispensing times

Pause times in days (24 h)
1 day up to 24 months
Lubricant volume
250 cm³ or 500 cm³

Service temperature for the mechanical component

–20 up to +60 °C (–4 to 140 °F)

Constant pressure build-up

Max. 25 bar
Assembly with tubing of ≤5 m

Type of protection

IP 65

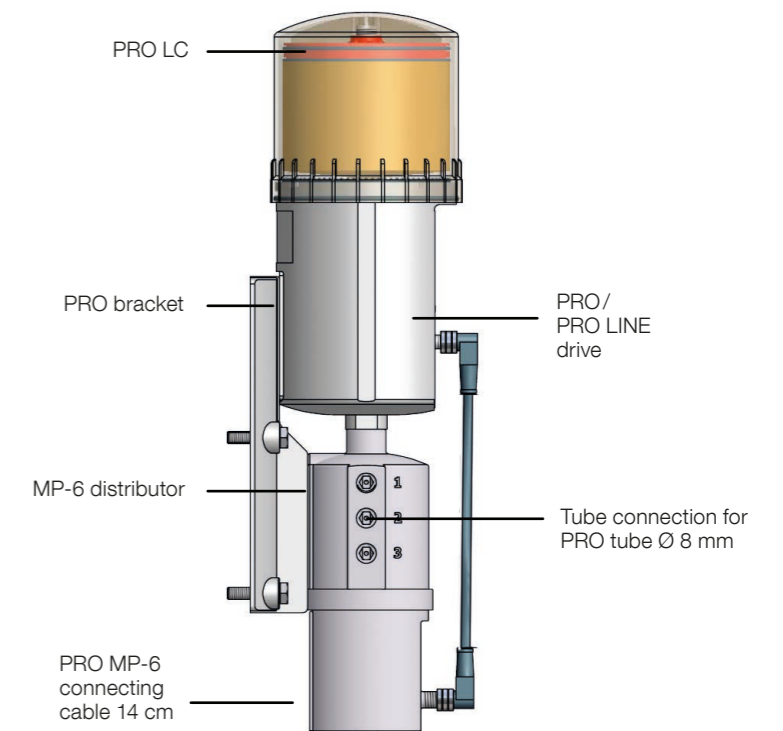

Klübermatic PRO C MP-6 and PRO C LINE

Precision lubrication systems with external current supply

The flexible multi-point lubrication system with 1 to 6 lubrication points

Klübermatic PRO C MP-6 and PRO LINE are power-supplied directly from the machine it is connected to and can be linked up to the machine's PLC unit for control and monitoring. Klübermatic PRO C LINE is a special multi-point lubrication system for linear guides. Lubricant metering can be precisely adjusted to the manufacturer's requirements.

The LC unit (LC = lubricant canister) of Klübermatic PRO is filled with 250 cm³ or 500 cm³ of grease and dispenses lubricant for up to two years. The high pressure build-up allows remote assembly by means of tubing up to 5 metres in length (per outlet) This increases workplace safety and allows reliable lubrication when the system is running.

Applications

Klübermatic PRO C LINE is mainly used for linear guides in a variety of sectors, e.g. automotive, steel and paper industries. Klübermatic PRO C MP-6 is mainly used for rolling and plain bearings, open gears and spindles.



Dispenser characteristics	Your benefit
Flexible settings possible (lubricant volume and pause times per outlet)	– The lubricant quantity to be dispensed can be set individually for each outlet – different quantities per outlet are possible with just one system – Individual setting of pause times and lubricant metering for each outlet
Push button with display and LED (for settings, display of the active outlets, display of the remaining dispensing time (PRO LINE) or of the remaining volume resp. (PRO MP-6))	– Easy handling and configuration of the lubricating system – Malfunctions of lubrication system are immediately displayed by the red/green LED light – Quick control of remaining dispensing time saves time and makes planning of PRO LC change easier
System purges	– For all outlets system purges can be triggered in the pause times – Peak loads can be compensated – Lubrication point can be flushed, e.g. in order to supply fresh lubricant after longer periods of standstill

Technical information

Housing

Transparent plastic

Drive

Electromechanical, reusable

Current supply

External 15–30 V, 120 mA

Lubricant volume

250 cm³ or 500 cm³

Service temperature for the mechanical component

–20 up to +60 °C (–4 to 140 °F)

Constant pressure build-up

Max. 25 bar
Assembly with a tubing of ≤ 5 m

Standard and special lubricating greases up to NLGI 2

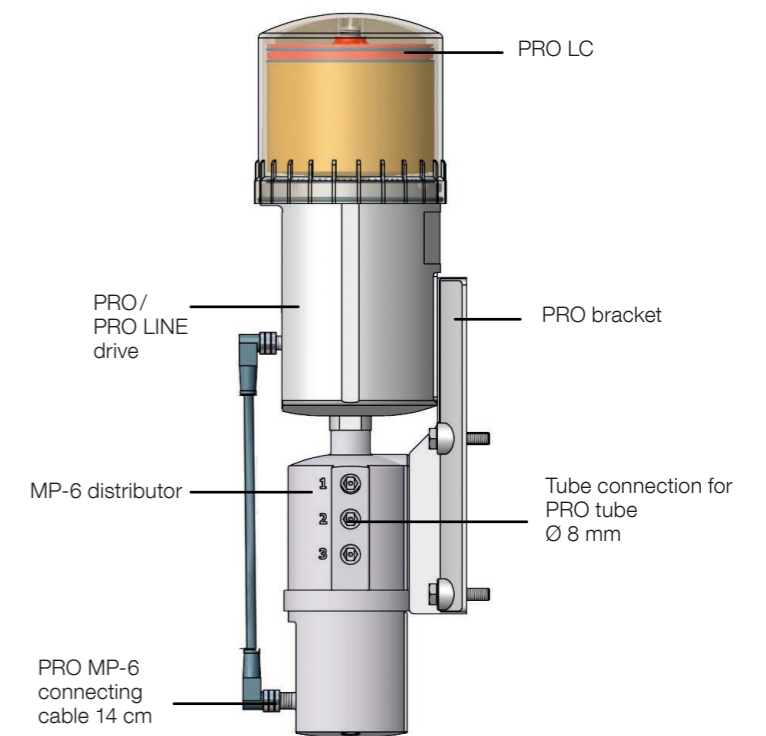

Klübermatic product range



A systematic approach to optimised lubrication

This table shows our lubricants which are available for use in Klübermatic lubricant dispensers. The applications and product data shown provide guidance for lubricant selection. Further data can be obtained from the product information leaflets. Of course, our lubricant experts will be pleased to consult you personally to make your choice.

Even if one of your applications is not in the list, please do not hesitate to contact our consultants: In many cases, Klübermatic lubricant dispensers can also be used for other components, for example shaft seals.

Lubricating greases	Lower service temperature (approx.)	Upper service temperature (approx.)	NLGI class	Application				
				Rolling bearings	Plain bearings	Open gears	Threaded spindles	Chains, ropes
Klübersynth UH1 14-151	-45 [°C] -49 [°F]	120 [°C] 248 [°F]	1	+++	+++	+	++	+
ISOFLEX Topas NCA 152	-40 [°C] -40 [°F]	140 [°C] 284 [°F]	2	+++	++	+	++	+
Klüberplex BEM 41-132	-40 [°C] -40 [°F]	150 [°C] 302 [°F]	2	+++	++	++	++	+
Klüberfood NH1 94-402*	-30 [°C] -22 [°F]	160 [°C] 320 [°F]	1/2	+++	+++	+	++	+
Klüberlub BE 71-501	-20 [°C] -4 [°F]	140 [°C] 284 [°F]	1	++	+++	++	++	+
Klübersynth BH 72-422	-20 [°C] -4 [°F]	220 [°C] 428 [°F]	2	+++	+++	+	+	+
STABURAGS NBU 12/300 KP	-20 [°C] -4 [°F]	130 [°C] 266 [°F]	1/2	+++	++	+	++	+
Klüberplex AG 11-462	-10 [°C] -14 [°F]	150 [°C] 302 [°F]	2	++	++	+++	+++	+++

Hint:









Many other speciality lubricants are available for use in the Klübermatic dispensers. Please contact your Klüber Lubrication specialist for more details.

Lubricating oils	Lower service temperature (approx.)	Upper service temperature (approx.)	Viscosity at 40 °C	Application				
				Rolling bearings	Plain bearings	Gear box	Threaded spindles	Chains, ropes
Klüberfood NH1 C 4-58*	-40 [°C] -40 [°F]	135 [°C] 275 [°F]	46	+	+	+	+	++
Klüberfood NH1 C 8-80*	-30 [°C] -22 [°F]	120 [°C] 248 [°F]	80	+	+	+	+	+++
Klüberoil 4 UH1-150 N*	-30 [°C] -22 [°F]	120 [°C] 248 [°F]	150	+++	+++	+++	++	+++
Klüberoil 4 UH1-220 N*	-30 [°C] -22 [°F]	120 [°C] 248 [°F]	220	+++	+++	+++	++	+++
Klüberoil GEM 1-100 N	-5 [°C] 23 [°F]	100 [°C] 212 [°F]	100	+++	+++	+++	++	++
Klübersynth CEH 2-100	0 [°C] 32 [°F]	280 [°C] 536 [°F]	100	+	+	+	+	+++





+++ Optimum performance/benefit ++ High performance/benefit + Standard

* This lubricant is NSF H1 registered and therefore complies with FDA 21 CFR § 178.3570. The lubricant was developed for incidental contact with products and packaging materials in the food-processing, cosmetics, pharmaceutical or animal feed industries. The use of this lubricant can contribute to increase reliability of your production processes. We nevertheless recommend conducting an additional risk analysis, e.g. HACCP.

Selected Klübermatic accessories

Connecting pieces	Denomination	Art. no.
	KM NOVA control unit with LCD display	838312
	KM STAR VARIO drive	838566
	KM STAR VARIO battery set	838060
	KM STAR CONTROL DRIVE 2.0	838393
	KM STAR CONTROL CABLE 2.0 (5 m)	838392
	KM STAR CONTROL CABLE 2.0 (10 m)	838394
	KM STAR support flange G1/4a x G1/4i (brass/plastic)	838401
	KM STAR CONTROL protective cap S60/M120 (plastic)	838259
	KM reducing adapter M6a x G1/4i – brass	838194
	KM reducing adapter G1/8a x G1/4i – brass	838190
	KM reducing adapter M8x1a x G1/4i – brass	838196
	KM reducing adapter M10x1a x G1/4i – brass	838197
	KM reducing adapter M6a x G1/4i – stainless steel	838032
	KM reducing adapter G1/8a x G1/4i – stainless steel	838222
	KM reducing adapter M8x1a x G1/4i – stainless steel	838224
	KM reducing adapter M10x1a x G1/4i – stainless steel	838225
	KM oil retention valve up to +60 °C (with plastic valve) – brass	838160
	KM oil retention valve up to +60 °C (with plastic valve) – stainless steel	838228
	KM oil retention valve up to +150 °C (with metal valve)	838217
	KM angle 45° G1/4a x G1/4i – brass	838176
	KM angle 90° G1/4a x G1/4i – brass	838180
	KM angle 45° G1/4a x G1/4i – stainless steel	838038
	KM angle 90° G1/4a x G1/4i – stainless steel	838221

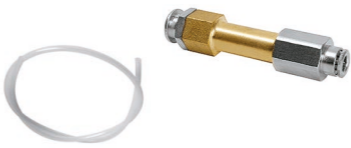
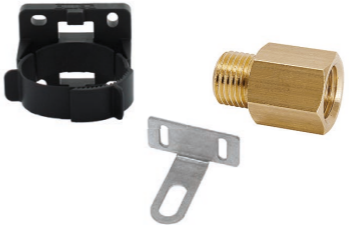
Please contact us for further accessories

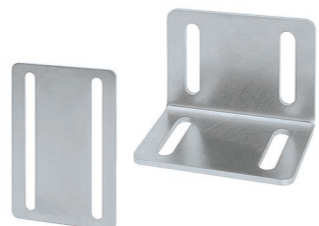
Connecting pieces	Denomination	Art. no.
	KM extension R1/4a x G1/4i 30 mm – brass	838212
	KM extension R1/4a x G1/4i 45 mm – brass	838213
	KM extension R1/4a x G1/4i 75 mm – brass	838214
	KM extension R1/4a x G1/4i 45 mm – stainless steel	838226
	KM extension R1/4a x G1/4i 75 mm – stainless steel	838227
	KM tube connection G1/4a straight, tube 8 mm	838161
	KM tube connection G1/4i straight, tube 8 mm	838156
	KM PSS tube up to +80 °C aØ 8 mm x iØ 6 mm (piece good)	838157
	KM PTFE tube up to +250 °C aØ 8 mm x iØ 6 mm (piece good)	838159
	KM tube pre-fill adapter (tube aØ 8 mm) brass	838164
	KM Multipurpose clip (for CLASSIC, FUTURA, FLEX, NOVA, STAR)	838402
	KM insert for holding device – brass	838170
	KM insert for holding device – stainless steel	838218
	KM holding device – stainless steel	838256
	KM lubricating brush Ø 20 mm G1/4i	838185
	KM lubricating brush 40 x 30 mm G1/4i top threaded connector	838186
	KM lubricating brush 60 x 30 mm G1/4i top threaded connector	838187
	KM lubricating brush 100 x 30 mm G1/4i top threaded connector	838188
	KM mounting plate 110 x 70 x 2.5 mm – hole spacing 45 mm	838247
	KM mounting angle 50 x 50 x 70 x 2.5 mm – hole spacing 45 mm	838248
	KM mounting angle 50 x 70 x 70 x 2.5 mm – hole spacing 45 mm	838249
	KM mounting angle 50 x 100 x 70 x 2.5 mm – hole spacing 45 mm	838250

Installation example

Example of direct installation of Klübermatic STAR VARIO

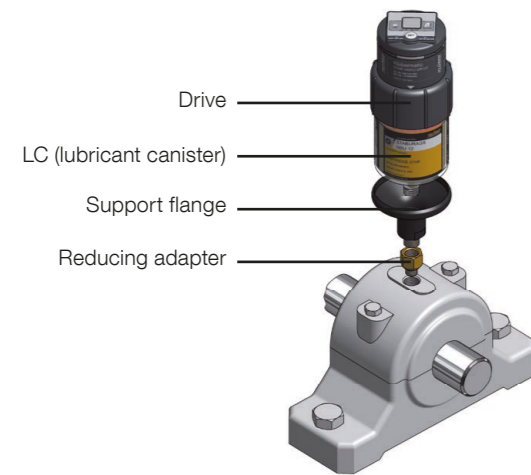

Example of remote installation of Klübermatic STAR VARIO

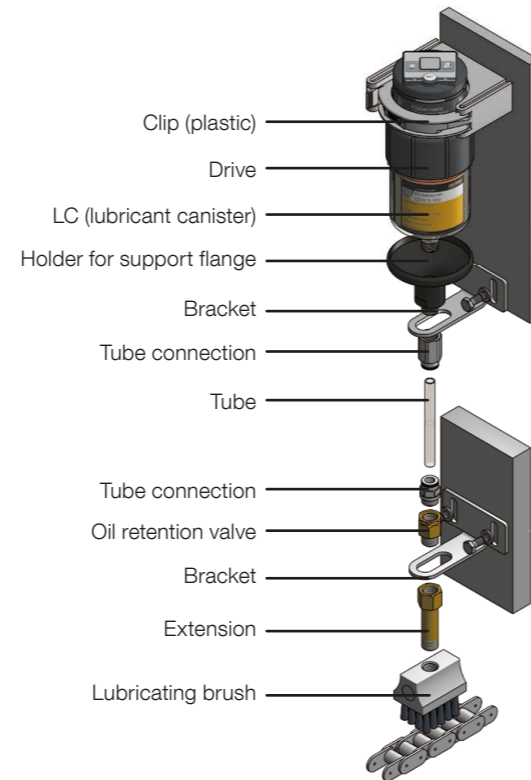

We offer the following two assembly kits containing the most important connecting parts for easier initial assembly of Flex, NOVA or STAR lubricant dispensers.

Klübermatic assembly kit for grease lubrication (article number 838561)	Klübermatic assembly kit for oil lubrication (article number 838562)
KM reducing adapter M6a × G1/4i – brass	KM reducing adapter M6a × G1/4i – brass
KM reducing adapter G1/8a × G1/4i – brass	KM reducing adapter G1/8a × G1/4i – brass
KM reducing adapter M8x1a × G1/4i – brass	KM reducing adapter M8x1a × G1/4i – brass
KM reducing adapter M10x1a × G1/4i – brass	KM reducing adapter M10x1a × G1/4i – brass
	KM oil retention valve up to +60 °C (with plastic valve) – brass

Publisher and Copyright:
Klüber Lubrication München SE & Co. KG

Reprints, total or in part, are permitted only prior consultation with Klüber Lubrication München SE & Co. KG and if source is indicated and voucher copy is forwarded.

The data in this document is based on our general experience and knowledge at the time of publication and is intended to give information of possible applications to a reader with technical experience. It constitutes neither an assurance of product properties nor does it release the user from the obligation of performing preliminary field tests with the product selected for a specific application. All data are guide values which depend on the lubricant's composition, the intended use and the application method. The technical values of lubricants change depending on the mechanical, dynamical, chemical and thermal loads, time and pressure. These changes may affect the function of a component. We recommend contacting us to discuss your specific application. If possible we will be pleased to provide a sample for testing on request. Products from Klüber Lubrication are continually improved. Therefore, Klüber Lubrication reserves the right to change all the technical data in this document at any time without notice.

Klüber Lubrication München SE & Co. KG
Geisenhausenerstraße 7
81379 München
Germany

Local first-instance court Munich, Germany
Certificate of registration 46624

www.klueber.com

Klüber Lubrication – your global specialist

Innovative tribological solutions are our passion. Through personal contact and consultation, we help our customers to be successful worldwide, in all industries and markets. With our ambitious technical concepts and experienced, competent staff we have been fulfilling increasingly demanding requirements by manufacturing efficient high-performance lubricants for more than 85 years.