



## Case Study

# Specialty lubricants boost high-pressure grinding roll energy efficiency.

**KLÜBER**  
**LUBRICATION**  
your global specialist

**Highly pressurized counter-rotating rolls that generate extreme stresses within material in the crushing zone make the HPGR process more efficient.**

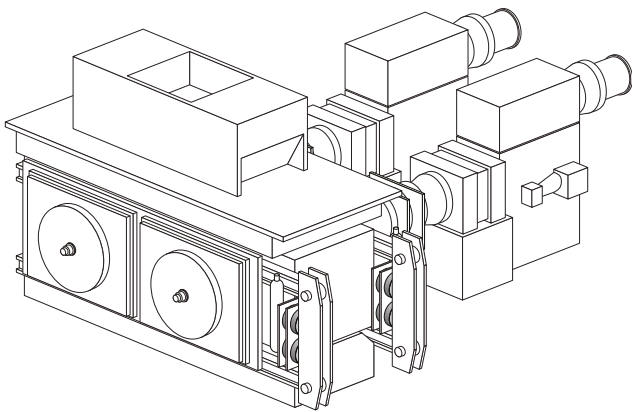

In crushing and grinding mining operations, high-pressure grinding roll (HPGR) technology is widely recognized as a more energy-efficient milling technology than conventional horizontal mills. Yet, it's possible to boost HPGR efficiency even more. Operations can use advanced specialty lubricants to reduce energy consumption, greenhouse gas emissions and operating costs, ultimately improving sustainability.

In the mining industry, crushing and grinding processes — known as *comminution* — consume a significant amount of energy. To put this consumption into numbers, industrial production in general accounts for

37% of energy use worldwide. Global mining activities comprise over 6%<sup>1</sup> of that amount, and comminution represents more than half<sup>2</sup> of that. The process consumes around 3% of the world's generated electric power usage.

At a time when mining operations are facing increasing electricity costs and environmental scrutiny, it's worth examining:

1. Energy efficiency and performance challenges encountered in HPGR comminution
2. Properties of lubricants that affect HPGR energy efficiency
3. The advanced specialty lubricants and services provided by Klüber Lubrication that help improve HPGR energy efficiency
4. The kWh savings actually obtained by a South American mining company that switched to advanced specialty lubricants from Klüber Lubrication

## Energy efficiency and performance challenges

What makes the HPGR process more efficient is its highly pressurized, counter-rotating rolls or tires that generate extreme stresses and microcracks within material in the crushing zone. This interparticle comminution process is so effective that HPGR comminution minimizes the need for downstream processing, which further reduces operational energy consumption.

The electric motor in HPGR machinery uses the most energy. It produces input torque into a planetary gearbox that turns the rotating tire shaft. The amount of kW it consumes is largely based on material load size, speed and temperature.

# Specialty lubricants boost high-pressure grinding roll energy efficiency.

Within the gearbox itself, moving parts are main sources of power loss.

A number of mechanical factors determine gearbox efficiency:

- Type of gear teeth (for example, helical or spur)
- Shape of gear teeth (for example, perfect involute)
- Roughness of the surface
- Type and design of the dynamic seals
- Dimensioning of bearings, gears, shafts
- Number, type and dimensioning of auxiliary drives
- Maximum torque to be transmitted
- Maximum peripheral speed

The lubricant inside the gearbox provides a protective film between gear teeth and rolling bearings to reduce wear and friction. Lubricants themselves contribute to two types of power losses:

## **Load-independent (also referred to as “basic” or “no-load”)**

**power losses.** These losses are mainly due to the immersion of the rotating elements in the oil sump.

When lubricant splashes and squeezes out of contact surfaces between gear teeth and rolling elements, energy is used but no actual work is performed. Specific areas of concern are gear and planet carrier windage (the drag of components spinning in fluid), oil trapping and/or churning and the viscous forces in rolling element bearings.

**Load-dependent power losses.** Friction in gear teeth meshing and the frictional moment in rolling bearings produce these losses.

A lubricant’s inherent lubricity — its ability to reduce friction between two objects, which is measured as the coefficient of friction — is decisive in reducing load-dependent power losses.

## **Properties of lubricants that affect gearbox efficiency**

The variables that influence gearbox efficiency can be broadly categorized as *extrinsic* and *intrinsic*. Extrinsic variables include the effects of material load volume, speed and temperature. Intrinsic variables include the effects of mechanical motion physics and fluid kinematics of the lubricant within the sump.

Energy efficiency is significantly affected by these lubricant properties:

- Viscosity
- Viscosity-temperature behavior
- Density
- Base oil type
- Additive system

## **Viscosity:**

Viscosity is the single most important characteristic of a lubricant. Generally defined as a fluid’s resistance to flow, viscosity is more specifically the internal friction of layers of fluid sliding by one another under shear stress. A lubricant’s resistance to flow is measured as *dynamic (absolute) viscosity*. The ratio between a lubricant’s absolute viscosity and its density is known as *kinematic viscosity*, which is measured in values of Stoke (St), centistoke (cSt) or mm<sup>2</sup>/s. When viewed together, *dynamic viscosity* provides information on how much force is needed to make the lubricant flow at a certain speed, and *kinematic viscosity* describes how fast the lubricant will move when a given force is applied to it.

Functionally, viscosity contributes significantly to forming the hydrodynamic film that protects bearings and gear teeth. Lubricants with high viscosities tend to cling to solid surfaces.

Viscosity correlates with the internal friction characteristics of the lubricant, such that:

- The higher the viscosity, the higher the hydrodynamic load capacity
- The lower the viscosity, the lower the internal friction losses

To boost gearbox efficiency, it’s critical to select the optimum lubricant viscosity. If the viscosity is too low, then hydrodynamic filming will be insufficient, resulting in excessive mechanical wear. On the other hand, if the viscosity is significantly higher than necessary for proper hydrodynamic film formation, then more energy will be used by moving elements in a heavier fluid.

## **Viscosity-temperature (V-T) behavior:**

The viscosity of a lubricating oil changes with temperature. Viscosity decreases as temperature increases and *vice versa*. The temperature dependence of the viscosity is not linear and can vary widely depending on the type of lubricating oil.

In gearboxes subject to a range of hot temperatures, the highest operating temperature of the components determines the high end of the viscosity range. To promote energy efficiency, lubricating oils with a lower V-T dependency — typically less viscous fluids — are applied. Two values are useful in describing a lubricant’s temperature performance:

- *Kinematic viscosity*, which is a value of the viscosity in terms of its density, as previously discussed
- *Viscosity index (VI)*, which measures the change of viscosity with temperature. The viscosity of lubricants with a higher VI is more stable across a range of temperatures. In general, synthetic oils are available with a higher VI and more stable viscosity than mineral oils as the temperature changes.

### Density:

A lubricant's density – its weight in relation to its volume – affects lubricant circulation and pumpability to reach areas in machinery where lubrication is needed. Heavy oils require more energy to move.

Consequently, density and viscosity both affect how much a lubricant contributes to energy efficiency. Selecting lubricating oils with high shear stability, a high VI and low density tend to boost energy efficiency.

### Base oil type:

Typical lubricants are mostly comprised of base oils and a smaller proportion – 5% to 10% – of additives. The base oil largely determines viscosity. Common base oils include the following:

**Mineral oils** are refined from crude oil and are classified by their VI and sulfur content.

**Synthetic oils** are made from chemical processes in compositions that include:

- Polyalphaolefins (PAO)
- Polyalkylene glycols (PAG)
- Polyol esters (POE)

Because the base oil is the main component in lubricants, proper base oil selection is critical in formulating lubricants that enhance energy efficiency without impairing performance. While bench tests can help, partnering with lubrication experts who conduct field measurements is the best way to truly determine which base oils are most effective in reducing friction and promoting gearbox efficiency.



Case Study Boosting High-Pressure Grinding Roll Efficiency  
19.09 Edition KLUUSA  
[www.klueber.com/blog/usa-canada](http://www.klueber.com/blog/usa-canada)

### Additive system:

Additives give a lubricant a number of additional benefits, such as improving VI, providing oxidative resistance, inhibiting foam, reducing friction, etc. Additives must be carefully selected for compatibility with the base oil and the application. Additive formulation is so complex that blends of synthetic and mineral oils can be used to enhance the additive's stability and function.

By influencing VI, thermal stability and the friction coefficient, additives enhance a lubricant's ability to improve gearbox efficiency. But the complexity of different base oil and additive formulations means that the lubricant manufacturer and oil analysis research are needed to determine the optimum formulations for a given application.

## Gear oils and services from Klüber Lubrication to improve energy efficiency

### Lubricant choices:

When choosing the optimum gear oil, determining the best balance of lubricant characteristics can be a challenge. On one hand, selecting a base oil with a high viscosity maintains thick oil films at higher temperatures. This lowers the coefficient of friction between metal-to-metal surfaces and enables high gear efficiency. On the other hand, selecting a highly viscous oil produces energy losses due to the hydrodynamics of moving mechanical components through a thick fluid. The resulting windage and churning losses will be most significant at start-up when operating temperatures are low and oil is more viscous.

Synthetic oils with a PAO base oil have a lower coefficient of friction compared to mineral oil at the same viscosity (Figure 1). This helps PAO oils reduce energy losses, although they have a limited viscosity range (Figure 2).

The lower coefficients of friction of PAG oils result in fewer power losses, making an even greater contribution to energy efficiency. For example, field tests have shown that Klübersynth GH 6 series lubricants with a PAG base oil used in a reducer gearbox decrease the total energy consumption up to 4%. In many cases, the energy savings effect can lead to a payback period of less than one year.

Base oil is only part of the picture. Additives can further minimize energy losses and impart many other valuable advantages such as extending service life. In general, properly formulated PAG oils have been found to contribute more to improving energy efficiency and reducing wear in HPGR planetary gearboxes.

Other advanced specialty lubricants from Klüber Lubrication are formulated to maximize efficiency and performance of electric-motor bearings. High-performance greases are available for main bearings and slideways, as well as biodegradable, eco-friendly hydraulic fluids based on synthetic ester oils.



# Specialty lubricants boost high-pressure grinding roll energy efficiency.

**FIGURE 1:**  
Friction coefficients measured by the Twin Disc Machine  
(Lower coefficient is better. Constants: 90° C oil injection temperature and viscosity of 150 ISO VG)

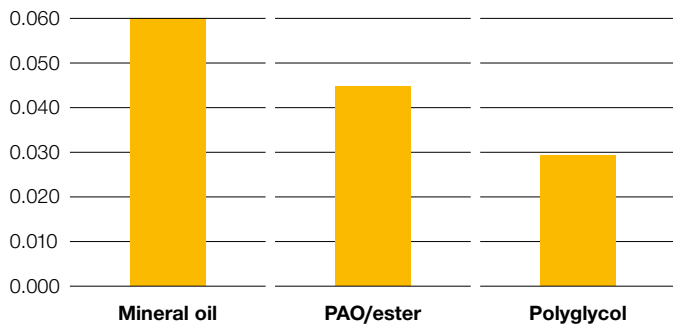

**FIGURE 2:**  
Relative energy efficiency contributions of mineral, synthetic PAO and PAG oils

Gear oil	Energy efficiency contribution	Base oil type	Upper service temperature	Range of ISO viscosity classes (max. range: 2 to 1,500)
Klüberoil GEM 1 N	+	Mineral	100° C	46 ... 1,000
Klübersynth GEM 4 N	++	PAO	140° C	32 ... 680
Klübersynth GH 6	+++	PAG	160° C	22 ... 1,500

## Using lubricant energy-optimization services:

Typically, end-users rely on the original equipment manufacturer’s (OEM) recommendations for gear oil. Of course, OEM lubricant expertise can vary, along with their application understanding. That’s why Klüber Lubrication offers a free program called KlüberEnergy, a unique service that measures the energy efficiency contribution of lubricants in specific applications, with the purchase of oil.

The program draws upon the experience gained from hundreds of projects where the selection of advanced specialty lubricants has been combined with KlüberEnergy consulting services. The result is a greater performance improvement than with a simple lubricant change.

What makes KlüberEnergy different from other programs is its deep level of detail and its strict adherence to international standards. The comprehensive program aligns with the International Performance Measurement and Verification Protocol (IPMVP), which is the measurement and verification standard for many countries including the United States. What’s more, KlüberEnergy meets ISO 50015, the standard for measurement and verification of energy performance for organizations.

ISO 50015 provides auditors a framework to confirm an organization’s energy performance and determine its certification to ISO 50001. ISO 50001 is a new standard for energy management systems to help organizations use energy more efficiently. An organization’s certification to ISO 50001 benefits the environment through the organization’s continually improved energy management. Certification can also mean considerable tax deductions for organizations in countries that provide such incentives.

An organization can be confident that it has the expertise essential to meet ISO 50001 when it partners with KlüberEnergy. Because KlüberEnergy follows ISO 50015, our experts know exactly what auditors look for and what is necessary to demonstrate true, continual energy improvement. Plus, an energy-efficient lubricant switch is an effective, easy and inexpensive way to improve energy management.

To determine the energy savings potential of your application, KlüberEnergy experts use a highly detailed methodology to measure the power consumption of your systems before and after lubricant retrofit. They provide credible, professional analysis of measured data, as well as translate these electrical readings into concrete financial and energy savings that matter.



Through energy measurement and energy and cost-savings reports, the service verifies the energy savings that result from a simple and affordable lubricant retrofit. HPGR applications are ideal for empirical validation because an HPGR process consumes a lot of electricity, runs many hours with heavy loads and employs large oil volumes. Energy-efficient lubricant retrofits in HPGR processes also have a very short payback time.

Over a period of a month, KlüberEnergy measures baseline energy consumption and other critical parameters to determine the kWh per ton with the existing oil under typical loads. This measurement provides a key performance indicator (KPI). Then the gearbox is retrofitted with the recommended gear oil from Klüber Lubrication. Gearbox seals, inner painting, sight glass and other material constructions are taken into account when selecting a particular lubricant formulation. The existing oil is pumped out or drained, then the sump is refilled with the new oil. KlüberEnergy gives the oil several weeks to circulate and react to gear surfaces before performing post-retrofit measurements. Comparing the performance of the two lubricants provides positive proof of kWh, cost and greenhouse gas reductions.

### Actual kWh savings obtained by a South American mining company

One remarkable HPGR application KlüberEnergy performed was for a South American mining company. At peak operations, the company's plants produced 24.9 million tons, 97% in pellets and 3% in iron ore fines.



An HPGR press with an hourly output of 917.7 tons per hour was selected for the oil retrofit. The previous mineral oil in the 264-gallon (1,000 liter) gearbox was drained and replaced with Klübersynth GH 6-320, a high-performance PAG oil.

For both the baseline lubricant and retrofitted Klübersynth GH 6-320, KlüberEnergy recorded three variables every 10 minutes for over a month: the power consumption, the distance between rollers and the in-feed rate. The frequency and duration of measurement ensured a huge amount of data.

Once the data was amassed, KlüberEnergy experts calculated the pressure based on roller distance and in-feed rate measurements. They then analyzed the pressure in relation to power consumption.

**FIGURE 3:**  
**Power Consumption vs. Mass Flow**

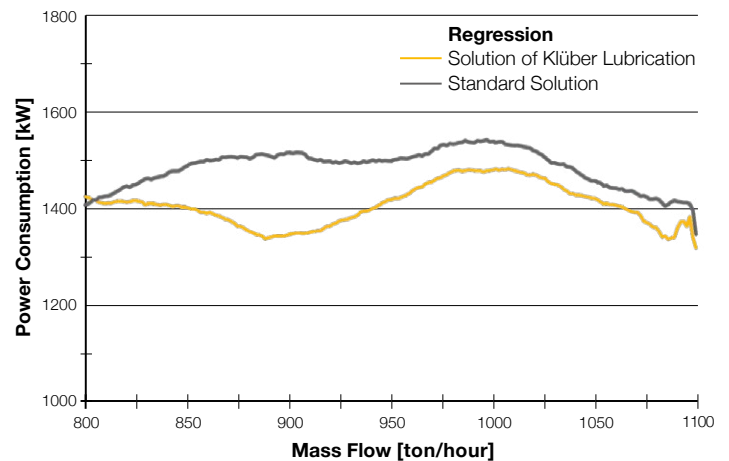

The pressure and power consumption were then charted to compare the performance of the baseline lubricant and Klübersynth GH 6-320. KlüberEnergy used the median of all measurement values to calculate the company's savings percentage.

When KlüberEnergy compared measurements between the two oils, Klübersynth GH 6-320 saved over 68.4 MWh per month in electricity. This savings reduces costs by \$40,284 per year, yielding a simple payback in only four months (Figure 4). When calculated over a full year, the oil saves 820.8 MWh in electricity use, which reduces greenhouse gas emissions by 580 metric tons.

**FIGURE 4:**  
**HPGR retrofit with Klübersynth GH 6-320**  
**(Values in USD)**

Baseline period	January 1 to June 15
Post-retrofit period	June 18 to August 14 (oil change performed June 17)
Total monthly production of mill	458,839 tons
Production rate	917.7 tons per hour
Monthly hours worked	500 hours
Verified energy savings	0.149 kWh per ton
Energy savings month/year	68.4 MWh per month/820.8 MWh per year
Cost of energy	\$49 per MWh
Cost savings month/year	\$3,357 per month/\$40,284 per year
Investment to change oil	\$14,000
Simple payback period	4 months
Greenhouse emission reduction	580 metric tons per year (equivalent to removing 123 vehicles from the road for a year)

The reliable methodology and adherence to international standards makes KlüberEnergy an industry standout. The comprehensive program delivers true value that companies can trust. KlüberEnergy services simplify the identification of lubricants that will produce significant energy savings and a fast payback.

## Conclusion

HPGR roller presses have inherently lower energy consumption per ton of ore processed than conventional horizontal mills. The use of advanced specialty lubricants from Klüber Lubrication formulated with a PAG base oil and special additives for the gearbox, as well as high-performing greases and hydraulic fluids for other system components, further improve energy efficiency and sustainability.

We recommend that when working with KlüberEnergy, customers start with a test on a single piece of equipment to identify and measure the specific tribological requirements and relevant factors that influence their application. We can help reduce the energy consumption of many more applications beyond HPGR roller presses, too.

Because multiple solutions are available, consulting with a Klüber Lubrication professional is required to select the best option that maximizes energy efficiency — or increases production rates with the same energy budget.

Visit [www.klueber.com/HPGR](http://www.klueber.com/HPGR) for more information and to arrange a consultation.

## References

1. [https://www.researchgate.net/figure/Total-energy-consumption-of-global-mining-activities-is-very-high\\_fig1\\_317123716](https://www.researchgate.net/figure/Total-energy-consumption-of-global-mining-activities-is-very-high_fig1_317123716)
2. <https://www.mining-technology.com/features/decarbonising-comminution-minings-biggest-energy-user/>